

EXPLOSION-PROOF CONNECTION HEAD WITH WELDED NPT PROCESS CONNECTION

How to build a part number:

To order an Applied Sensor Technologies temperature sensor, select the requirements for the categories listed below and fill in the corresponding boxes with your selection. Don't see exactly what you need? Give us a call!

SENSOR TYPE	ASSEMBLY STYLE	SHEATH DIAMETER	SHEATH MATERIAL	CALIBRATION	HOT JUNCTION	SHEATH LENGTH	OPTIONS

SENSOR TYPE

MI – Mineral insulated thermocouple

ASSEMBLY STYLE

78 – Sheath with cast aluminum head and 1/2" NPT welded stainless steel process connection; head CSA/FM approved for Class I, Division 1, Groups B, C, D; Class II, Groups E, F, G; screw cover with chain and gasketed o-ring, meets NEMA 4; ceramic terminal block; 1/2" NPT conduit connection (Note: for spring-loaded fitting, see Style 75 and add optional head).

SHEATH DIAMETER (in inches)

- 4** – 1/8 (0.125)
- 6** – 3/16 (0.188)
- 7** – 1/4 (0.250)
- 9** – 3/8 (0.375)

SHEATH MATERIAL

- 3** - 316 stainless steel
- 5** - Inconel® 600

CALIBRATION – Standard limits

- J** – Single J **JJ** – Dual J
- K** – Single K **KK** – Dual K
- T** – Single T **TT** – Dual T
- E** – Single E **EE** – Dual E

Special limits are available – consult AST

HOT JUNCTION

- G** – Grounded junction
 - U** – Ungrounded junction
 - E** – Exposed junction
- (Note: lengths over L84 will be shipped coiled unless otherwise specified at time of order)

SHEATH LENGTH

L# – (e.g., L6 = 6 inch sheath, L12.5 = 12.5 inch length)

OPTIONS – see page 1-3b

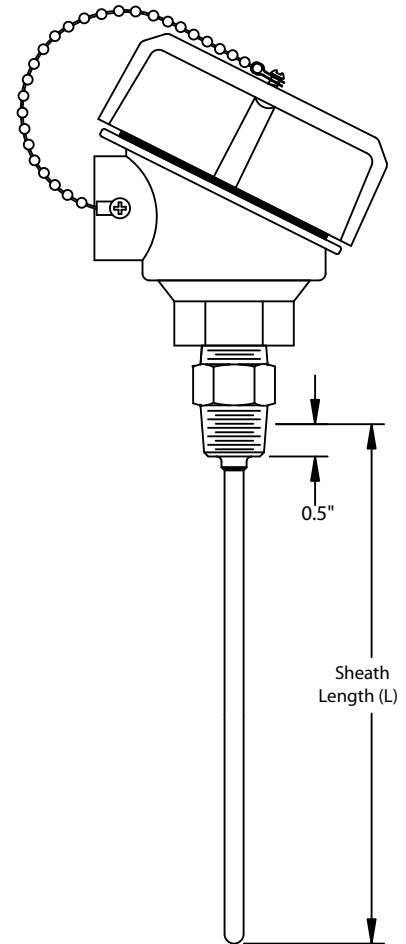

STYLE 78

AVAILABLE OPTIONS and MODIFICATIONS

ASSEMBLY OPTIONS	
Option Code	Description
TAG1	Stainless steel tag and wire
PC25	1/4" NPT process connection
PC75	3/4" NPT process connection
CAL1	Calibration, NIST traceable calibration [specify point(s)]
CRT1	Certificate of conformance
TRANSMITTERS – For complete specs, see Transmitters section	
TR11	4-20 mA, 2-wire transmitter, single input, isolated output; specify range and units of measure (e.g., 0-200°C)
TR12	4-20 mA, 2-wire transmitter, single input, non-isolated output; specify range and units of measure (e.g., 0-200°C) and terminal head with *.
TR13	HART®/ 4-20 mA, 2-wire transmitter, single input, isolated output; specify range and units of measure (e.g., 0-200°C) and terminal head with *.

EXPLOSION-PROOF TERMINAL HEAD OPTIONS		
Option Code	Process Connection	Conduit Connection
Cast aluminum; screw cover with chain; o-ring gasket (Gasket rated to 100°C exposure); ceramic terminal block; FM/CSA approved for Class I Div. 1, Groups B, C and D; Class II Groups E, F and G; internal ground screw.		
HD71	1/2"	3/4"
Epoxy-coated, same specs as HD71		
HD80	1/2"	1/2"
HD81	1/2"	3/4"

Note: See Accessories section for additional specs.